

**GAS TURBINES GENERATE  
OUR BUSINESS**

**TURBINE SUPPORT SERVICES**



## **501K ENGINE REPAIR & SERVICE CENTRE**

The global economic situation has undoubtedly had an impact on many industries and many companies. Although business remains difficult, there does at last seem to be some light at the end of the tunnel.

Since the opening of the 501-K engine repair and service centre in 2008, TSS has very successfully processed a number of 501-KB, KB5 and KB5S engines. This has seen TSS placing its repair and refurbished product into a number of continents, including South America and Europe.

As our web site states; *an English company with a global reach*. So it is with this business concept in mind that TSS has projected its image from our workshops in Coventry, UK.

Being both a young and dynamic company, TSS has placed a lot of effort into meeting and matching its customers needs and product demands with our services and technical abilities. Our matched service concepts are continually focused toward providing our clients a quality product that maintains both quality and commercial expectation.

Through a private business re-investment process, TSS has equipped its workshop services with all the

specialist engine tooling that is required to undertake full 501KB/KB5KB5S turbine and hot-section refurbishments. This investment has seen the latest digital upgrades being applied to our dynamic rotor balancing equipment, with a new vertical balancer for all static wheel balancing being installed shortly.

Although this technical workshop ability was grown to support the TSS 501K rental engine fleet, a number of commercial clients have approached TSS in recognition of our service abilities and the quality of our product.

Should the services of TSS be of interest to you, please feel free to contact us and we would be pleased to present you with a quotation.

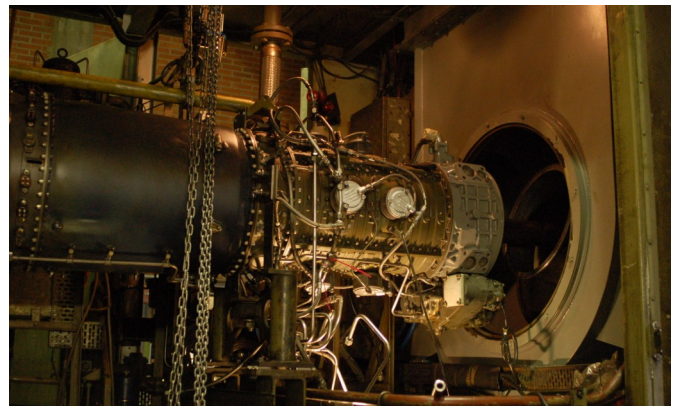

### **TSS LEASE ENGINES**

To support 501-K engine operators, TSS has evolved a fleet of 501K engines which are available for use as either short term engine rentals or as long term en-

gine leasing. Our rentals engines are offered in support of operators that perhaps wish to defer engine overhaul / repair activities or wish to send their engine away to a facility for work. A TSS rental engine is offered in isolation to its

in-house engine repair and refurbishment services, so should you choose to send your engine elsewhere for repair but want to use our rental engine whilst enjoying our competitive rates, then that is fine with us.

For further details of services supplied by Turbine Support Services, please contact our team at :-

**Turbine Support Services Ltd**

Tel : +44 (0) 20 8640 3857

Mobile: +44 (0) 7730 590 415

e-mail: [sales@turbinesupportservices.co.uk](mailto:sales@turbinesupportservices.co.uk)

web: [www.turbinesupportservices.co.uk](http://www.turbinesupportservices.co.uk)



**GAS TURBINES GENERATE OUR BUSINESS**

## TSS 501K MODULE EXCHANGE PROGRAMME

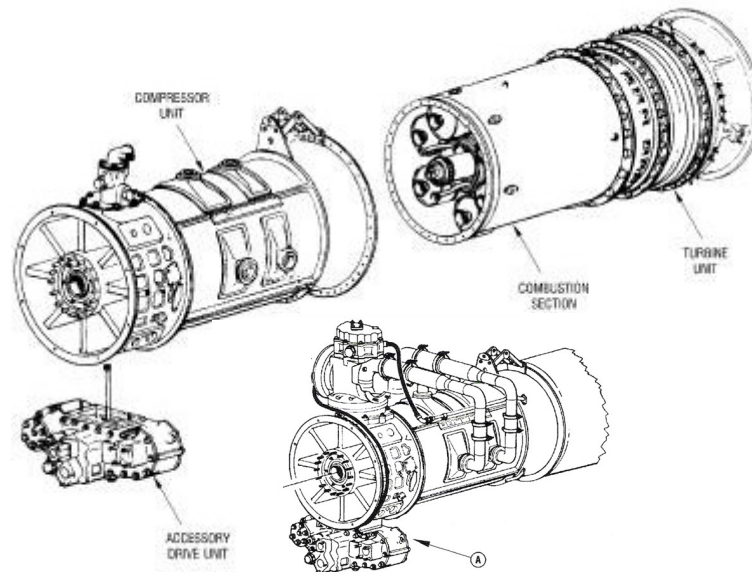

The 501-KB/KC module exchange programme developed by Turbine Support Services is a truly basic concept through which engine repair and overhaul services can be brought to the site of the engine operator.

By design the 501K engine is made up of three basic modules; the compressor, the accessory gearbox and the hot section. Traditionally, 501K series engines were sent away for overhaul every thirty thousand (30K) fired hours. However, through a mixture of product developments and material enhancements, we now routinely expect to see 501KB5 turbine achieve over forty thousand (40K) fired hours. KB5 Compressors routinely achieve in excess of fifty thousand (50K) fired hours, with accessory gearboxes achieving in excess of forty five thousand (45K) fired hours.

One downside to these improvements is now there is a considerable step change in the respective overhaul lives of the three engine modules.

One question in the heads of many of today's 501K operators is; how can one embrace the maximum available service life of a module without placing the entire engine at risk of failure by pushing any one module too far? Conversely, if a module is removed from service too early then potential operational value is lost.

In answer to this dilemma, TSS has promoted a 501K module exchange programme.

Simply put; TSS propose to supply an exchange module to the clients site at the optimum time, so to maximise revenue yield from the equipment, whilst minimising the risk of equipment failure to acceptable levels.

The physical exchange of the modules can be undertaken by either the operators existing service / maintenance provider or by TSS personnel. It is your choice.

Each module is supplied with a comprehensive warranty on both parts and material and workmanship. Modules can be supplied embodied with either NEW Rolls-Royce material or certified non-OEM material.

All modules will have been refurbished by an accredited 501K engine overhaul facility and will be supported by an applicable certificate of conformity.

Interested? Then why not ask for a quote...

For further details of this plus any other services offered by TSS, please contact us.