

GAS TURBINES GENERATE OUR BUSINESS



501K ENGINE REPAIR & SERVICE CENTRE

Since the opening of the 501K engine repair and service centre in 2008 a number of 501KB, KB5 and KB5S engines have been successfully processed. In February 2011 we were pleased to add to this list our first 501K boosted engine.



This engine is somewhat unique as it is one of only two 501KH7 engines ever produced by Rolls Royce Allison. This shop visit will see the KH7 being refurbished and reconfigured to a KB7.

Being a young and dynamic company the aim and focus of TSS is towards meeting customers needs and matching these needs with our services and technical abilities. These matched service concepts are continually reviewed ensuring that our product reflects client expectations at all levels.

To support our mechanical activities, TSS has equipped its workshops with a range of specialist 501K engine tooling required to undertake full 501KB/KB5/KB5S/KB7 hot section inspections, repairs and refurbishments. This investment has seen the latest digital upgrades being applied to our rotor balancing equipment.

Although this technical workshop ability was grown to support the TSS 501K rental engine fleet, a number of commercial clients have approached TSS in recognition of our service abilities and the quality of our product. Should our scope of services be of interest to your operation, please contact TSS for a quotation without obligation.



TSS LEASE ENGINES

To give support to 501K engine operators, TSS has evolved a fleet of 501K engines which are available for use as either short term engine rentals or on a long

term engine leasing basis. Our rental engines are intended to support operators that perhaps wish to defer an engine overhaul activity or simply wish to send their engine away to a facility for work and seek a rental engine .

When you rent or lease a TSS 501K engine you are not obliged to send your engine to TSS for work. Should you wish to send your engine to another engine shop, why not just enjoy our competitive per fired hour rental rates?.

For further details of services supplied by Turbine Support Services, please contact our team at :-

Turbine Support Services Ltd

Tel : +44 (0) 20 8640 3857

Mobile: +44 (0) 7730 590 415

e-mail: sales@turbinesupportservices.co.uk

web: www.turbinesupportservices.co.uk



TSS 501K MODULE EXCHANGE PROGRAMME

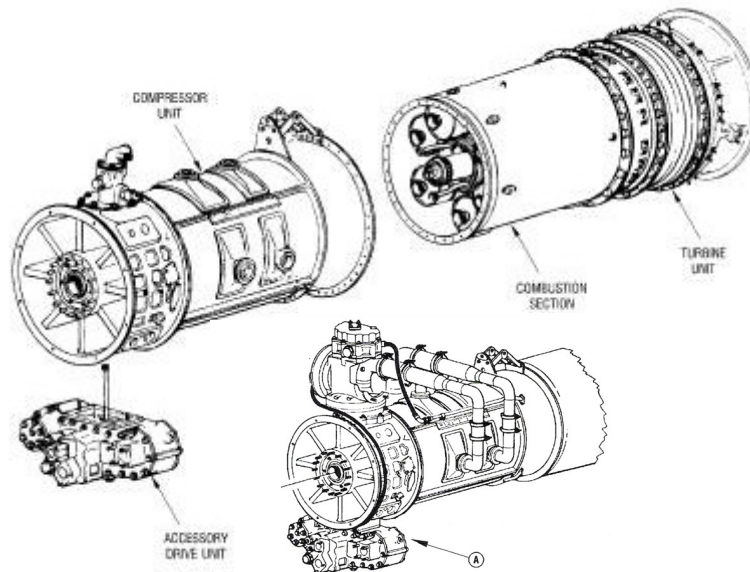

The 501KB/KC module exchange programme developed by Turbine Support Services is a truly basic concept through which engine repair and overhaul services can be brought to the site of the engine operator.

By design the 501K engine is made up of three basic modules; the compressor, the accessory gearbox and the hot section. Traditionally, 501K series engines were sent away for overhaul every thirty thousand (30K) fired hours. However, through a mixture of product developments and material enhancements, we now routinely expect to see 501KB5 turbines achieve over forty thousand (40K) fired hours. KB5 compressors routinely achieve in excess of fifty thousand (50K) fired hours, with accessory gearboxes achieving in excess of forty five thousand (45K) fired hours.

One downside to these improvements is now there is a considerable step change in the respective overhaul lives of the three engine modules.

One question in the heads of many of today's 501K operators is; how can one embrace the maximum available service life of a module without placing the entire engine at risk of failure by pushing any one module too far? Conversely, if a module is removed from service too early then potential

operational value is lost. In answer to this dilemma, TSS has promoted a 501K module exchange programme.

Simply put; TSS propose to supply an exchange module to the clients site at the optimum time, so to maximise revenue yield from the equipment, whilst minimising the risk of equipment failure to acceptable levels.

The physical exchange of the modules can be undertaken by either the operators existing service / maintenance provider or by TSS personnel. It is your choice.

Each module is supplied with a comprehensive warranty on both parts and material and workmanship. Modules can be supplied embodied with either NEW Rolls-Royce material or certified non-OEM material.

All modules will have been refurbished by an accredited 501K engine overhaul facility and will be supported by an applicable certificate of conformity.

Interested? Then why not ask for a quote...

For further details of this plus any other services offered by TSS, please contact us.